



Smart Architecture of Espadana

Designing, Production, Customization and Consultant Service
in Network and Fiber Optic System



Technical Specification

SAE-PE16160F-DG-NMS

16 ports PoE 10/100Mbps switch & 2 Up-link Gigabit Combo port (SFP+Rj45)





16 ports PoE 10/100/1000Mbps switch & 2 Up-link Gigabit Combo port (SFP+Rj45)

Product Description

- E ports support power over Ethernet for Power Devices, Support IEEE802.3af standard
- guaranty per ports (15.5 watt per port)
- 16 × RJ45 ports 10/100Mbps auto-sensing
- 2xCombo ports (Gigabit SFP + Gigabit RJ45), Uplink ports: 1.25Gbps fiber interface
- Strong, reliable power supply
- 250 watts total power output
- Architecturally store-and-forward protocol
- Natural cooling by using method of Fan less design
- Metal compact package design, suitable for desktop or 1-U rack mount
- Remote Web interface for Switch management

Full Description

This SAE-PE16160F-DG-NMS management PoE switch prepare a field that power and data can feed from a single point, using Power over Ethernet (PoE) over a single cable. 16 fast Etrnet ports and 2-Combo ports (gigabit SFP + gigabit RJ45) prepare any 1000Mbps link and the rest of 16ports can supply industry-standard IEEE 802.3af power for every PoE standard devices. Regards to using advanced auto-sensing algorithm the SAE-PE16160F-DG-NMS gives power only to IEEE802.3af front-end devices, so don't worry about connecting PoE or non-PoE devices to this feeder. Additionally, this good gives up the power when PoE devices are disconnected. Intelligently, this manageable PoE Switch SAE-PE16160F-DG-NMS can recognized automatically PoE demands of devices, speed, duplex, and cable type using Auto Uplink™. Remarkably, it has two gigabit fiber ports (SFPs) that helps smart CCTV network designers to improve their planning and use the switch intelligently. Additionally, network planners would control the network parameters via web management system. SAE-PE16160F-DG-NMS made by high quality of components were rigorous screened, have superior performance in stability, environmental adaptability. The product planned in a way of better resistance.



16 ports PoE 10/100/1000Mbps switch & 2 Up-link Gigabit Combo port (SFP+Rj45)

Application

- IP cameras monitoring systems and transmitting systems
- Access points wireless systems and transmission data
- IP telephone, virtual PABX and intelligent unmanned systems
- Management and support Intelligent transportation supervisory (ITS)
- Monitoring TV medical and management
- School, campus, and... monitoring and remote control
- Wireless systems (AP) and transmission data

Technical Specification

Product	SAE-PE16160 F-DG-NMS	
Performance		
Capacity in Millions of Packets per Second (64-byte packets) (Buffer Memory)	4M	
Switching Capacity in Gigabits per Second (Gbps) (Bandwidth)	64 Gbps (non-blocking)	
Maximum Network Delay in microseconds(us)	maximum delay less than 20(us)	
MAC Size	16K	
MTBF	190,000hours	
Interface		
Ports	16 PoE 10/100Mbps 2 Up-link Gigabit Combo port (SFP+Rj45)	
protocol		
Store-And-Forward		
Supported Network Protocols and Standards		



16 ports PoE 10/100/1000Mbps switch & 2 Up-link Gigabit Combo port (SFP+Rj45)

<ul style="list-style-type: none"> ➤ IEEE 802.3i 10BASET ➤ IEEE 802.3u 100BASETX ➤ IEEE 802.3x Flow Control 	
Cable length detection	100m
Power	
Output	Total: 250W
Input	AC100-240V 50/60Hz (every country use a custom power plug)
Environmental Aspects	
Dimension	440×280×44mm
Working environment	Operating Temperature: 0 ° ~ 55 ° C Storage Temperature: -20 ° ~ 75 ° C Operating Humidity: 10% ~ 95%, non-condensing

Network Management Features	
Interface	IEEE802.3X (Full-duplex) Broadcast storm control based on port speed The speed limit of the message flow in the access port. The minimum particle size is 64Kbps. Port temperature protection setting Port green Ethernet Energy-saving setting
Layer 2+	L2+ Network management IPV4/IPV6 management Static route, Default route @ 128 pcs, APR @ 1024 pcs
VLAN	4K VLAN based on port, IEEE802.1q VLAN based on the protocol VLAN based on MAC Voice VLAN, QinQ configuration Port configuration of Access, Trunk, Hybrid



16 ports PoE 10/100/1000Mbps switch & 2 Up-link Gigabit Combo port (SFP+Rj45)

Port Aggregation	LACP, Static aggregation Max 10 aggregation groups and 8 ports per group.
Spanning Tree	STP (IEEE802.1d), RSTP (IEEE802.1w), MSTP (IEEE802.1s)
Multicast	IGMP Snooping v1/v2, Max 1024 multicast groups, Fast log out MLD Snooping v1/v2, Multicast VLAN
Port Mirroring	Bidirectional data mirroring based on port
QoS	Diff-Serv QoS, Priority Mark/Remark 8*Output queues of each port 802.1p/DSCP priority mapping Queue Scheduling Algorithm (SP, WRR, SP+WRR) Flow-based Packet Filtering Flow-based Redirection Flow-based Rate Limiting
ACL	L2 to L4 packet filtering, matching first 80 bytes message. Provide ACL based on MAC, Destination MAC address, IP Source, Destination IP, IP Protocol Type, TCP/UDP Port, TCP/UDP Port Range, and VLAN, etc. Port-based Issuing ACL. ACL based on port and VLAN
Security	User hierarchical management and password protection SSH 2.0, SSL, Port isolation, ARP message speed limit Broadcast storm control, Backup for host datum IEEE802.1X & MAC address authentication Mac black holes, IP source protection AAA & RADIUS, MAC learning limit ARP inspection, Anti-DoS attack IP-MAC-VLAN-Port binding
DHCP	DHCP Client, DHCP Snooping, DHCP Server, DHCP Relay



16 ports PoE 10/100/1000Mbps switch & 2 Up-link Gigabit Combo port (SFP+Rj45)

Management	Console/AUX Modem/Telnet/SSH2.0 CLI Web Management (HTTPS) Download & Management on FTP, TFTP, Xmodem, SFTP, SNMP V1/V2C/V3 One-key recovery NTP, System work log, Ping Test Cable Diagnose, LLDP CPU instant utilization status view ONV NMS - Smart Network Management System Platform (LLDP+SNMP)
System	Web browser: Mozilla Firefox 2.5 or higher, Google browser chrome V42 or higher, Microsoft Internet Explorer10 or later; Category 5 Ethernet network cable TCP/IP, network adapter, and network operating system (such as Microsoft Windows, Linux, or Mac OS X) installed on each computer in a network

Product Size Display

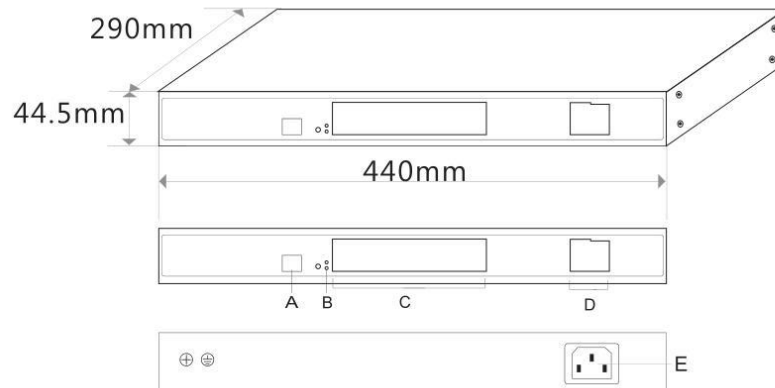

- A. Console Port
- B. Working Indicator
- C. 16*10/100M PoE Ports
- D. 2*10/100/1000M Combo Ports
- E. Power Input Port AC100-240V, 50/60Hz



16 ports PoE 10/100/1000Mbps switch & 2 Up-link Gigabit Combo port (SFP+Rj45)

Product Application Display

